

TEENAGE MUTANT NINJA TURTLES™

SEWER SKATEBOARD

Assembly:

Attach base to skateboard as shown. Attach stickers as indicated.

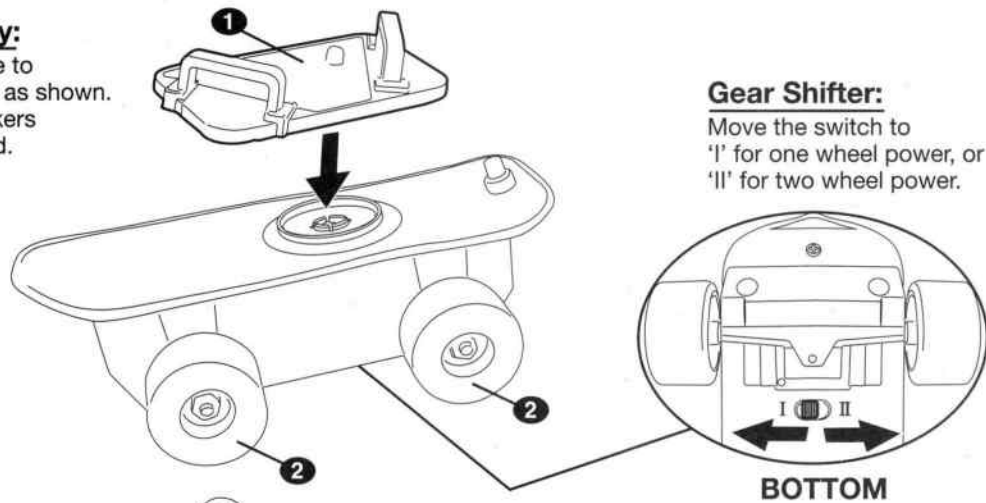

Gear Shifter:

Move the switch to 'I' for one wheel power, or 'II' for two wheel power.

BOTTOM

To Rev Up:

Grab skateboard and push forward with all four wheels on a safe surface to rev up, lift up the skateboard off surface. Rev up 4 times in a row is designed to produce maximum power. Skateboard works best on hard flat surfaces.

Important: Keep fingers away from rotating rear wheels.

Front Side Ollie:

Set 'II' wheel power. Position the figure and base on the skateboard as shown below. Rev up (push forward) 1 time. (slow power) Release skateboard softly on all four wheels aiming straight at stunt ramp.



360° Power Wheelie N' Roll:

Set 'I' wheel power. Position the figure and base on the skateboard as shown below. Rev up (power) 1 time. (slow power) Release skateboard onto the back two wheels.



360°:

Set 'I' wheel power. Position the figure and base on the skateboard as shown below. Rev up (power) 1 time. (slow power) Release skateboard onto the back two wheels.



Wall Wack Power Wheelie:

Set 'I' wheel power. Position the figure and base on the skateboard as shown below. Rev up (power) 2 times. (medium power) Release skateboard softly on all four wheels aiming at a safe wall to hit.

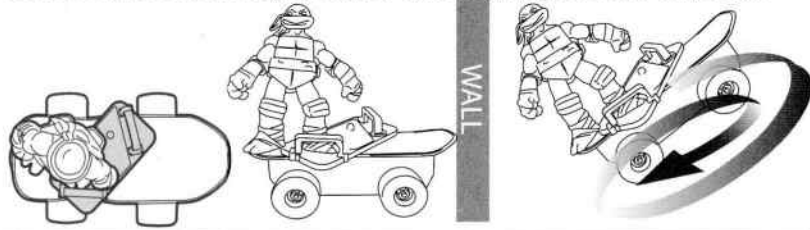

Kick Turn At Lip:

Set 'I' wheel power. Position the figure and base on the skateboard as shown below. Rev up (power) 1 time. (slow power) Release skateboard softly on all four wheels aiming at ramp.



Double Wall Wack Attack:

Position a bad guy close to a corner. Set 'I' wheel power. Position the figure and base on the skateboard as shown below. Rev up (power) 4 times (maximum power). Release skateboard softly on all four wheels aiming at a safe corner. It may take some practice or repositioning to attack the bad guy.

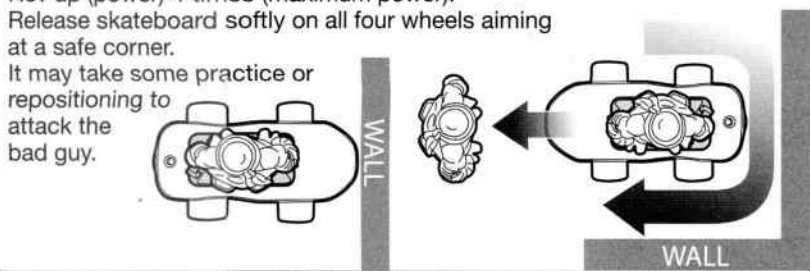

Wall Wack 180°:

Set 'I' wheel power. Position the figure and base on the skateboard as shown below. Rev up (power) 3 times. (strong fast power) Release skateboard softly on all four wheels aiming at safe wall to hit.

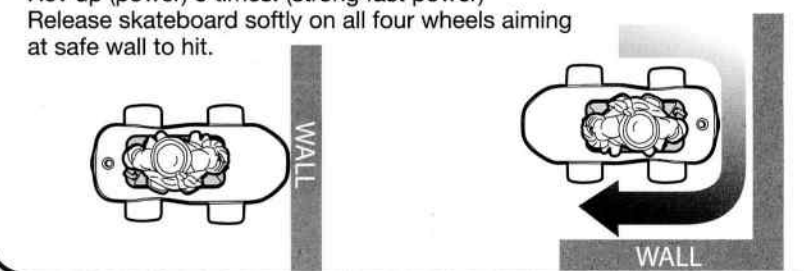

Mid Ramp Kick Turn:

Set 'I' wheel power. Position the figure and base on the skateboard as shown below. Rev up (power) 1 time. (slow power) Release skateboard softly on all four wheels aiming at ramp.

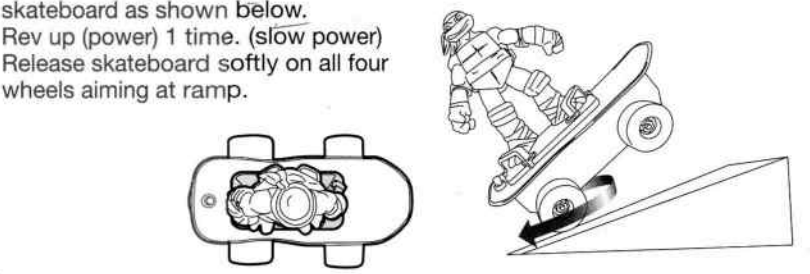

Power Wheelie N' Roll:

Set 'II' wheel power. Position the figure and base on the skateboard as shown below. Rev up (power) 1 time. (slow power) Release skateboard quickly on back two wheels tilted at an angle.



Manual:

Set 'II' wheel power. Position the figure and base on the skateboard as shown below. Rev up (power) 1 time. (slow power) Release skateboard onto the back two wheels.

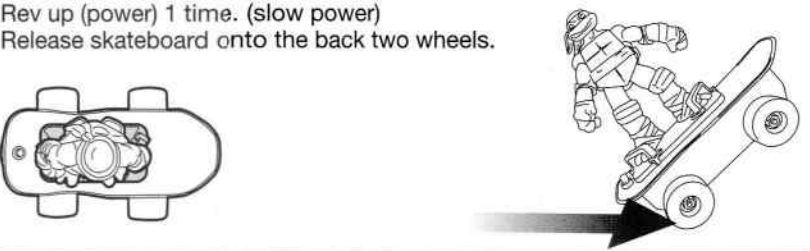

Wall Wack & Turn:

Set 'I' wheel power. Position the figure and base on the skateboard as shown below. Rev up (power) 2 times. (medium power) Release skateboard softly on all four wheels aiming at safe wall to hit.

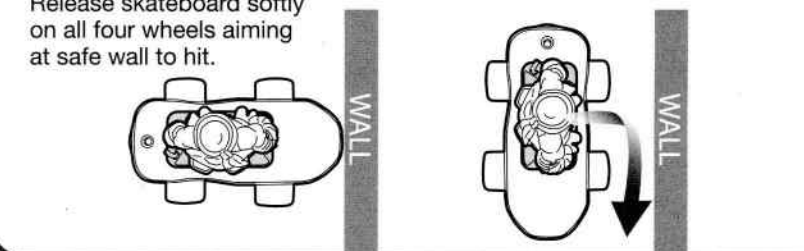

Not all figures will perform all tricks as shown. Figure not included. For more detailed instruction information visit www.Playmatestoys.com

Ages 4 and up
Asst. #94000
Item #94273